

# *Continuum*<sup>TM</sup> Continuous Motion Tray Packer

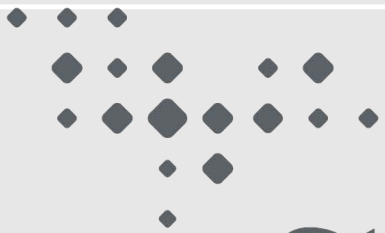

**Standard Knapp**

# Continuum™ Features

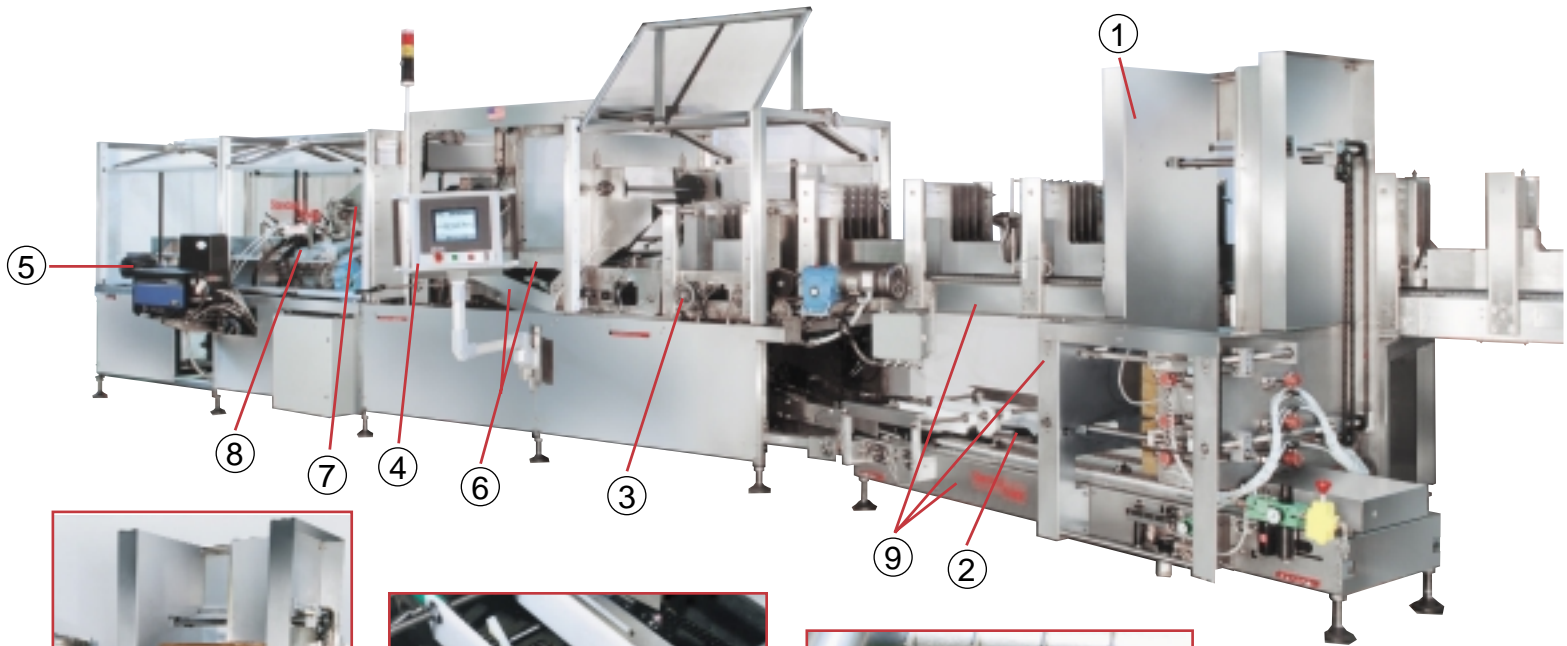

① Easy, continuous loading, vertical stack, high capacity blank magazine.



② Positive tray transport keeps control of tray during transfer from magazine.



③ Servo-controlled grouper provides positive product handling and quick and easy changeover.



④ Graphic display, touch screen operator interface simplifies operation and provides checklist for changeover functions.



⑤ "Phaser" adjustment allows easy changes to compression pocket size for optimum squareness of trays.



⑥ Inline product handling allows narrow footprint for efficient use of plant space.

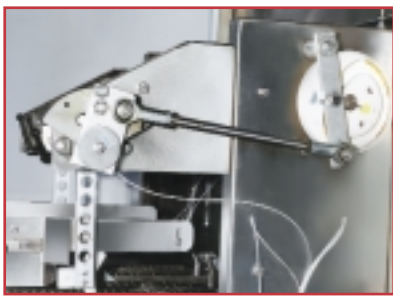

⑦ Mechanically timed flap tuckers ensure consistent tray forming at varying speeds.

⑧ Four-gun gluing option ensures trays are sealed under all conditions.



⑨ Stainless steel frame construction (optional) reduces machine maintenance requirements and allows for easy machine cleaning.

# Continuum

## Description of Operation

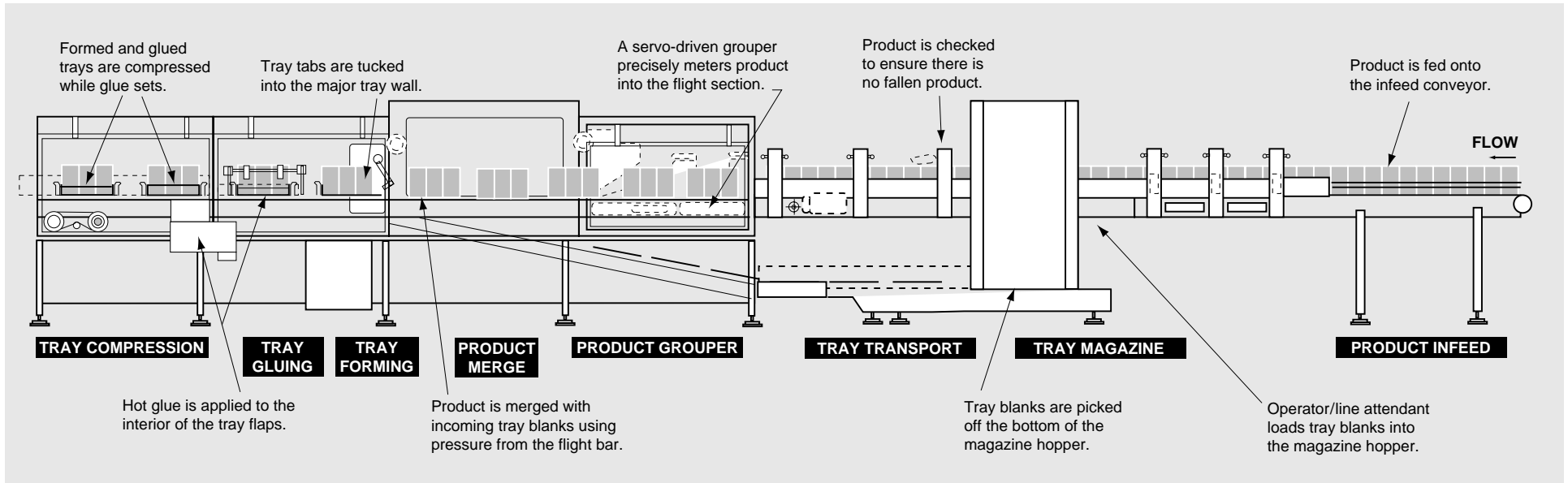

## The Fastest Changeover in the Industry

- “By the Numbers” changeover system ensures prompt start-up with no tweaking
- Step-by-step checklist on touch screen
- No tools required for adjustments
- Minimum change parts (lane spacers)

## Options Available

- Stainless or mild steel construction
- Four-gun gluing
- Manual partition section
- Versions for 50 TPM, 70 TPM or 100 TPM
- Automatic central lubrication system
- Integration with shrink wrapper



**Standard Knapp**

**STANDARD-KNAPP, INC.**

127 Main Street, Portland, CT 06480 U.S.A.

**SALES PHONE:** (860) 342-1100, ext. 239

**SALES FAX:** (860) 342-1557

**EMAIL:** info@standard-knapp.com

**WEB SITE:** www.standard-knapp.com

# Continuum™ Floor Plan

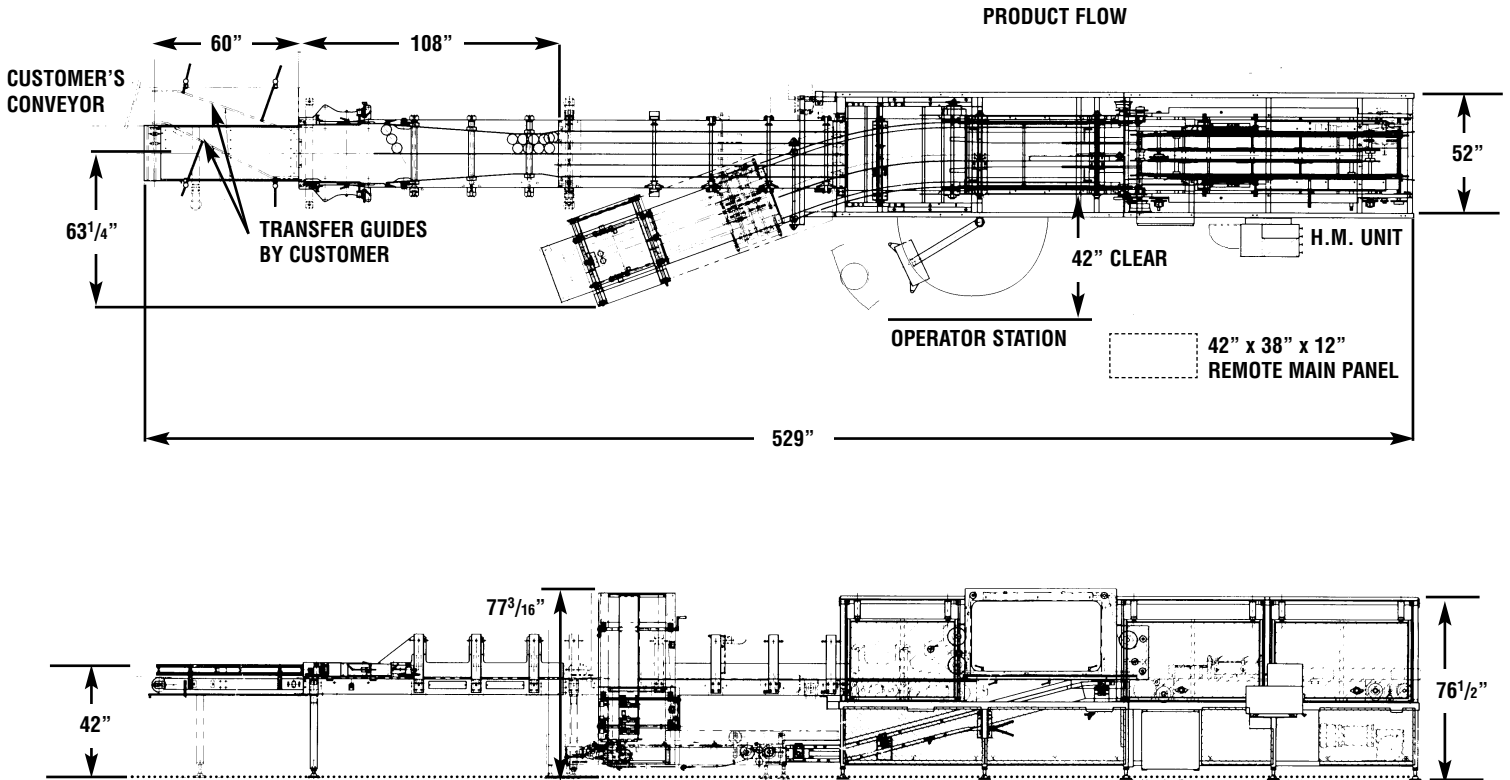

## Specifications\*

### Speed:

50, 70, 100 TPM

### Product Sizes:

202 dia. to 603 dia.

### Products:

Glass jars, metal and fiber cans

### Magazine:

Continuous loading vertical  
hopper, appr. 500 blank capacity

### Pack Patterns\*\*:

2 x 2, 3 x 2, 4 x 3, 6 x 4

### Air Requirements:

5 scfm @ 90 psi

### Power Requirements:

460 v, 60 cycle, 3 phase,  
30 Amp drop

### Main Control Enclosure:

NEMA 4, painted steel-it

### Machine-Mounted Enclosures:

NEMA 4

### Controls:

24 vDC with A-B SLC 500  
Series processor

### Operator Interface:

Computer Technology  
Corporation touch screen

\* Specifications subject to change without notice.

\*\* Pack patterns vary for different diameter products.



**StandardKnapp**

## STANDARD KNAPP, INC.

127 Main Street, Portland, CT 06480

**SALES PHONE:** (860) 342-1100, ext. 239

**SALES FAX:** (860) 342-0782

**EMAIL:** info@standard-knapp.com