

*Continuum*TM

High Speed Tray Packer & Shrink Wrapper



Standard Knapp

ContinuumTM **High Speed Tray Packer & Shrink Wrapper**

Already proven at dozens of installations in the food and beverage industry, the Continuum Tray Packer is the best machine for achieving efficient operations. Including the optional integrated Shrink Wrapper and Tray Stacker, it has inherent product flexibility and changeover features that are unparalleled in the industry. Whether you are running glass, PET, metal or fiber cans into chipboard or corrugated trays, the Continuum is the right choice.

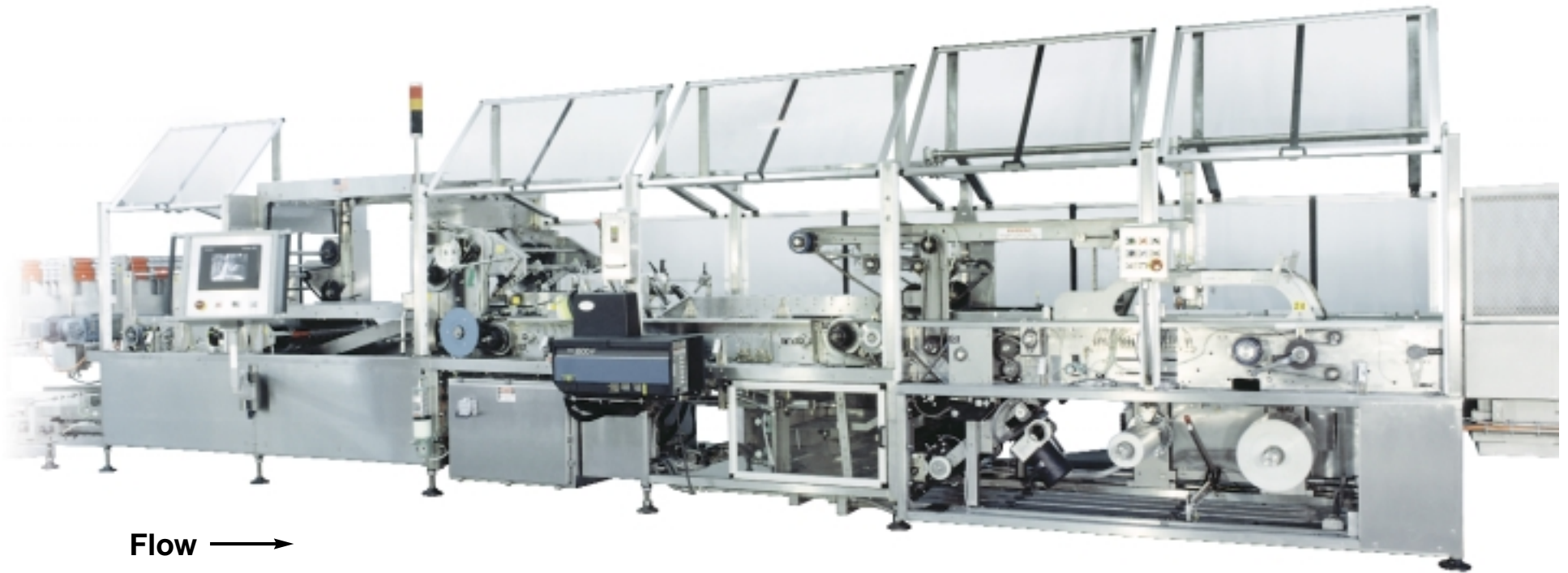

Machine Benefits

Reliable design provides high line efficiency

- Zero-gap infeed eliminates jams
- Positive tray magazine
- Precise servo grouper
- Four-gun glue system



296-I CHANGEOVER SETTING CHART

STEP	DESCRIPTION	FACTORY SETTING		FIELD SETTINGS
1	Zero-Gap Spacers (3)			
2	Infeed Spacers (5)			
3	Grouper Spacers (3)			
4	Pattern-Forming Guides			
5	Gap Plate	L	R	
6	Relief Gate Stop	L	R	
7	Stepped Fill-in Guide			
8	Down Product Detector			
9	Flight Bar Width	L	R	
10	Tray Flap Phaser			
11	Flap Tucker Width	L	R	
12	Flap Catcher Plates	L	R	
13	Tray Filler Plates	L	R	
14	Glue Gun Width	L	R	
15	Glue Gun Angle	L		
16	Tray Pocket Phaser			
17	Compression Width			
18	Magazine Width			
19	Magazine Length			
20	Tray Delivery Width			
21	Film Width			

Quick changeover with no tweaking

- Simple, by-the-numbers system
- No additional tools necessary
- Color-coded lane spacers

Flexibility

- Handles largest diameter range in the industry, with minimal change parts
- Loose containers and multipacks
- PET, metal, glass, HDPE, fiber cans
- Corrugated or chipboard trays
- Free-standing or integrated shrink wrapper
- Integrated tray stacker option



Low-maintenance design

- Machine drive has independent clutch protection
- Stainless Steel construction
- Gull Wing Guards allow complete access to all points
- Cluster lubrication with optional automatic pump

Continuum™

Description of Operation

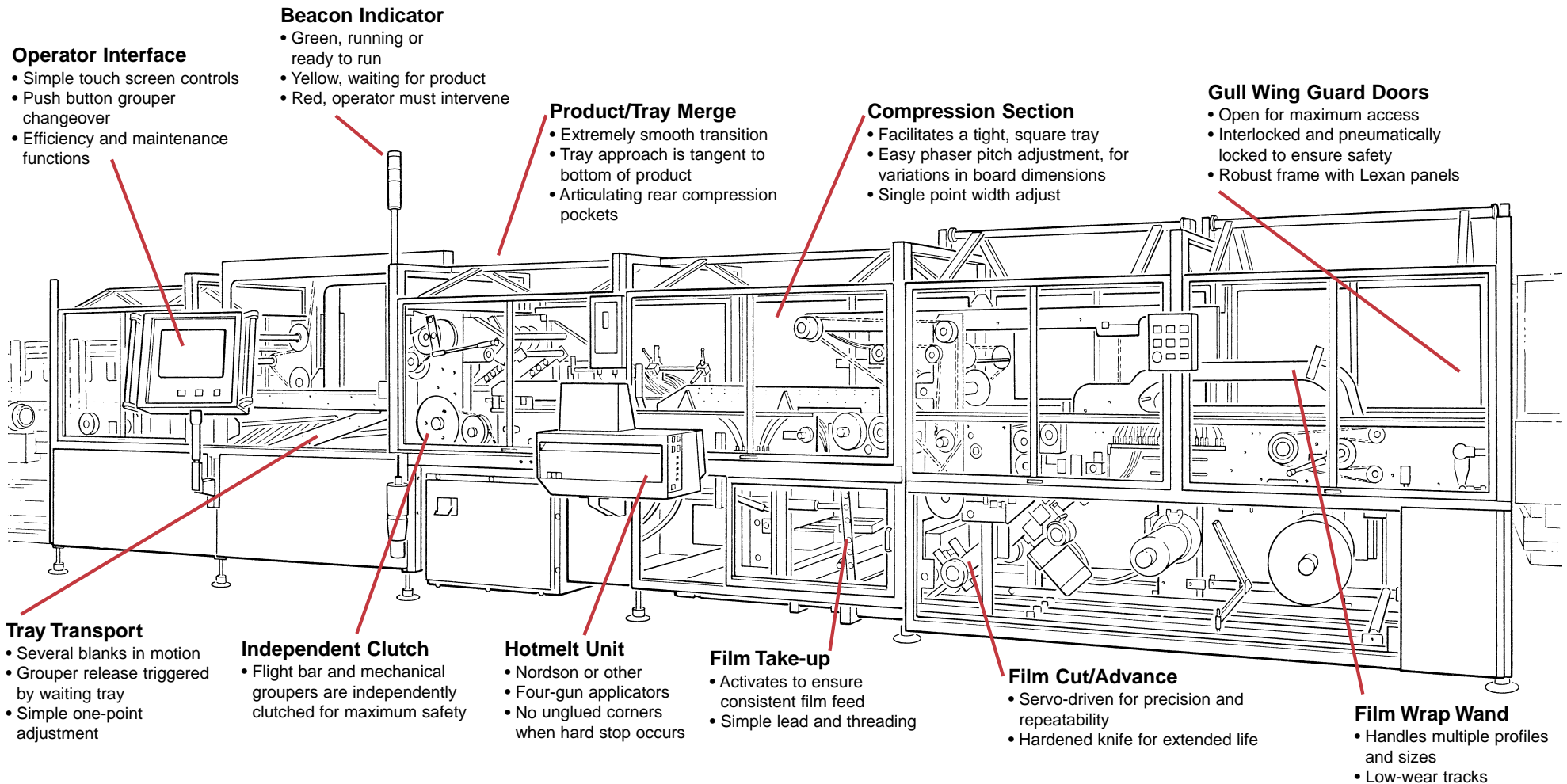

Continuum Grouper Module

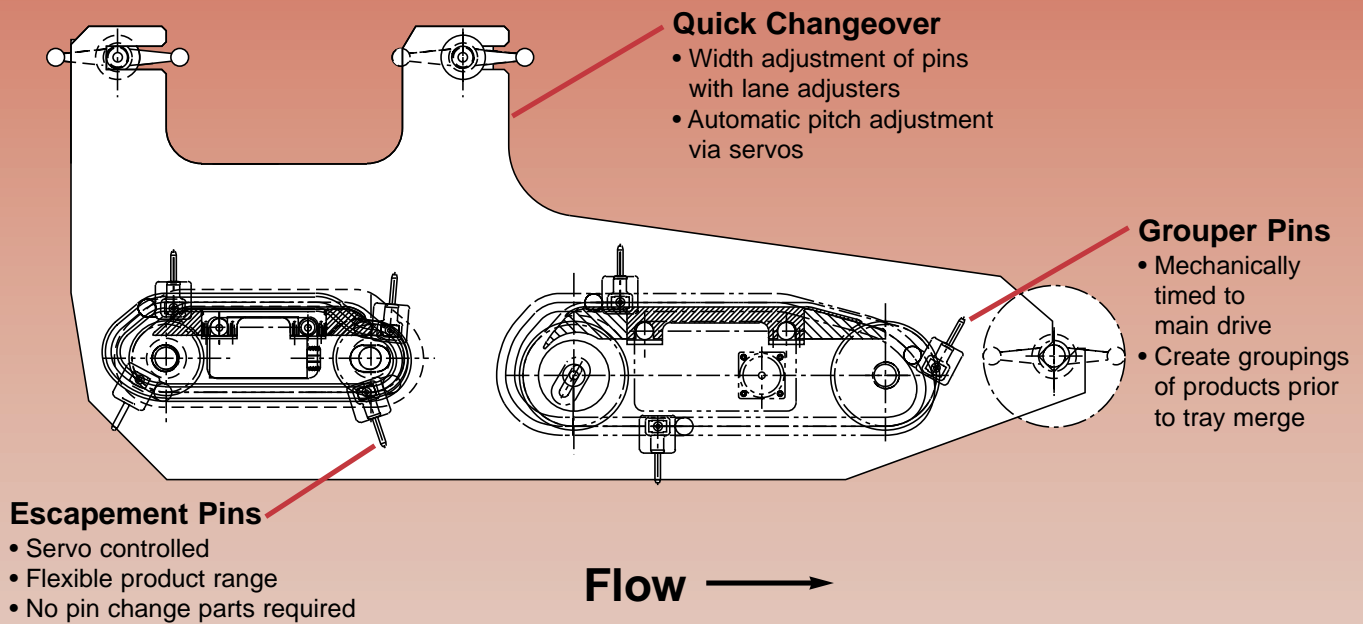

Continuum Tray Magazine

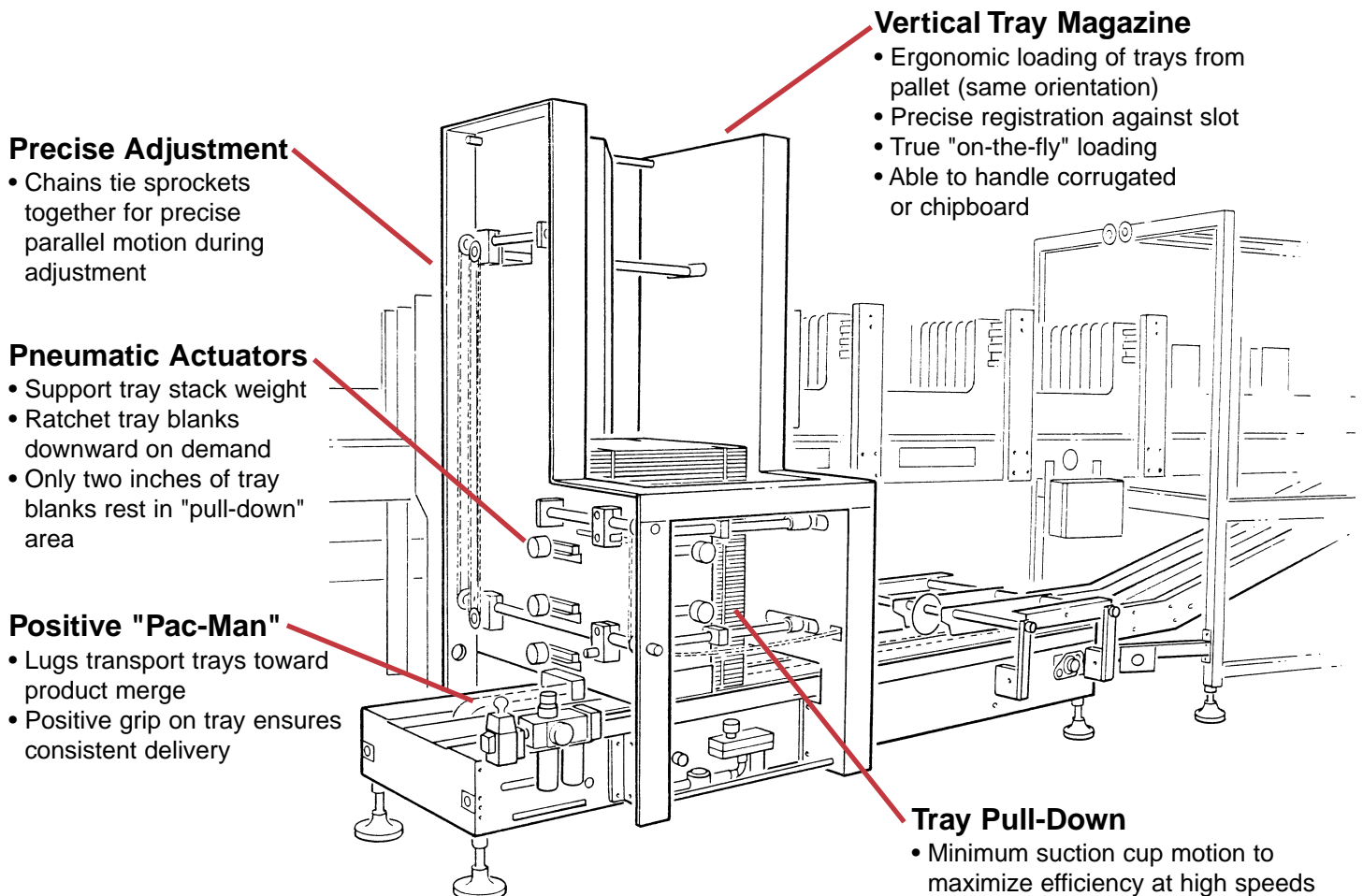

Continuum™ Floor Plan

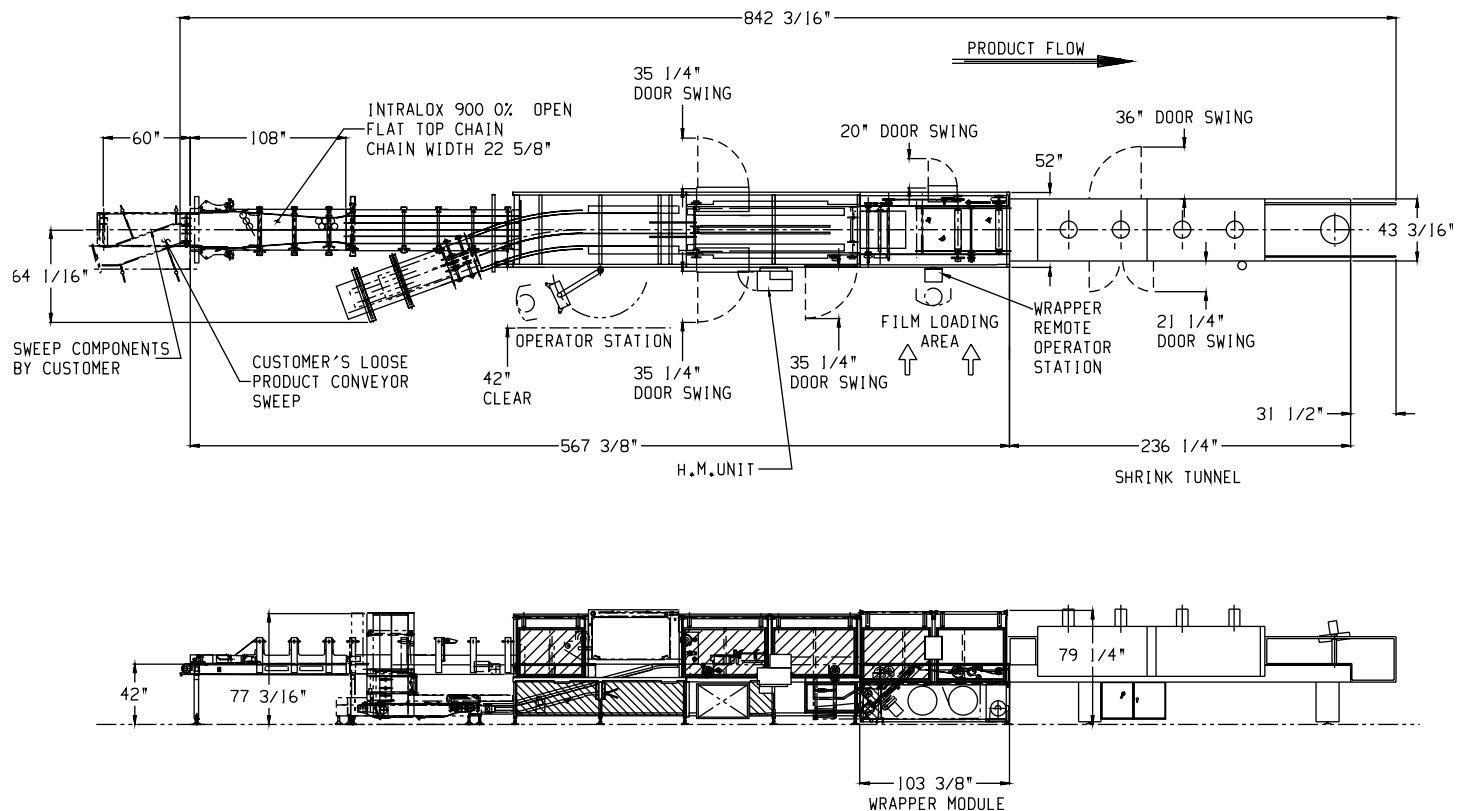

Specifications*

Speed:

50, 70, 100 TPM

Product Sizes:

1³/₄" to 6¹/₄" dia.

Products:

Glass jars, PET, HDPE, metal and fiber cans, HiCone, shrink bundles, paperboard overwrap, and others

Tray Magazine:

Continuous loading vertical hopper, appr. 500 blank capacity

Film Magazine:

21" diameter
25" roll length

Film Seal:

Overlap weld

Air Requirements:

5 scfm @ 90 psi

Power Requirements:

460v, 60 cycle, 3 phase, 200A

Servo Motors:

A-B 1394 and A-B 1398
motion controller

Tunnel Heat:

72 kw

Main Control Enclosure:

NEMA 4, painted Steel-it®

Machine-Mounted Enclosures:

NEMA 4

Controls:

24 vDC with A-B SLC 500,
Modicon, or other

Operator Interface:

PanelView 1000 or other

* Standard-Knapp is committed to continuous product improvement. Specifications subject to change without notice.



Standard Knapp

STANDARD-KNAPP, INC.

127 Main Street, Portland, CT 06480 U.S.A.

SALES PHONE: (860) 342-1100, ext. 239

SALES FAX: (860) 342-0782

EMAIL: info@standard-knapp.com

WEB SITE: www.standard-knapp.com