

ULTIMATE Is Our Standard™

StandardKnapp
StandardKnapp

an EMPLOYEE owned company



PikMore™ Uncaser

High speed without sacrificing precision bottle handling



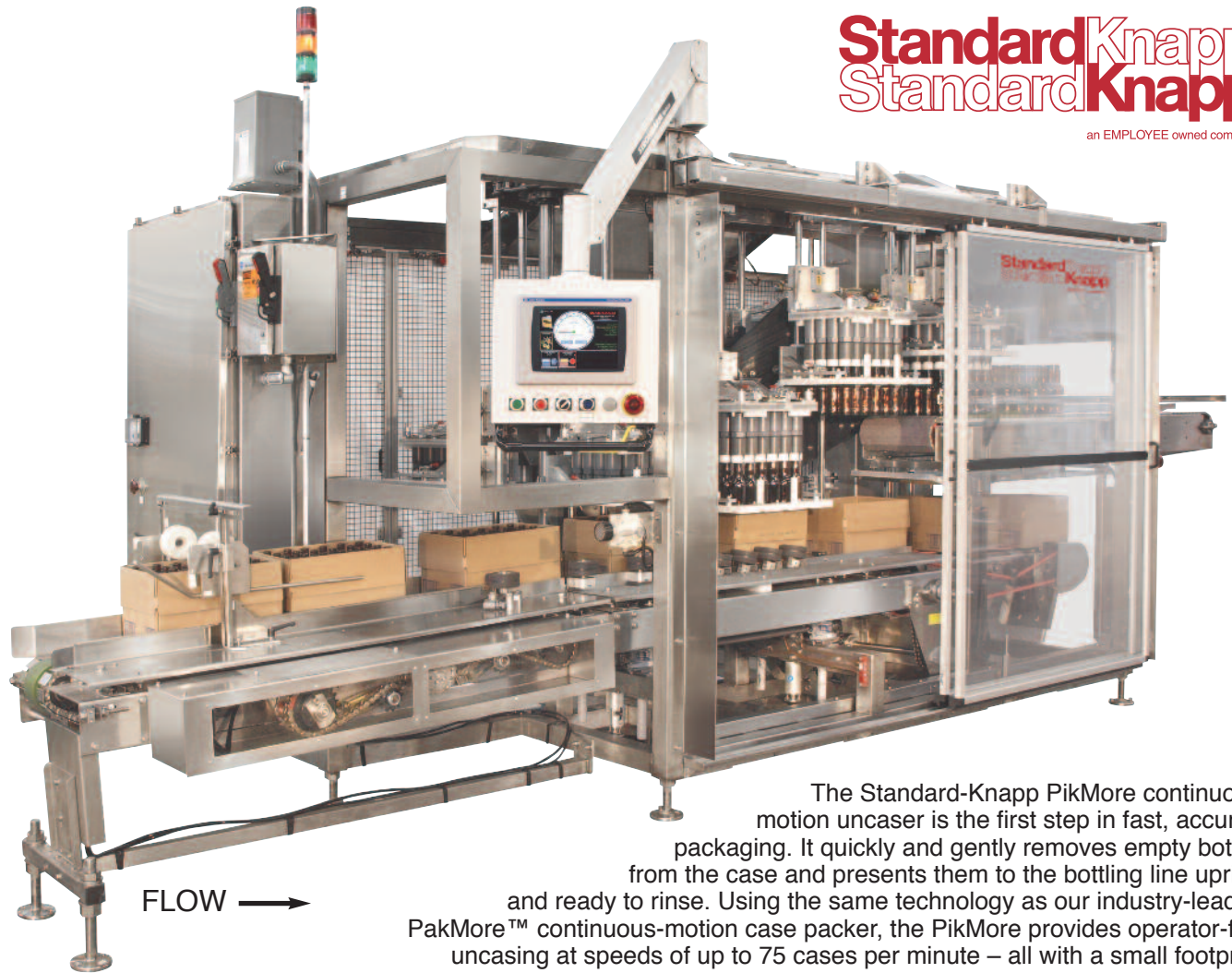

The Standard-Knapp PikMore continuous-motion uncaser is the first step in fast, accurate packaging. It quickly and gently removes empty bottles from the case and presents them to the bottling line upright and ready to rinse. Using the same technology as our industry-leading PakMore™ continuous-motion case packer, the PikMore provides operator-free uncasing at speeds of up to 75 cases per minute – all with a small footprint.

The PikMore™ Uncaser – The first step in perfectly finished product.

Robust Construction

Stainless steel tubular frame

High Reliability

Designed for 24/7 operation

Simple Operation

Fast, easy operation

Easy Walk-by Maintenance™

See-through safety guarding

Flexible and Adaptable

To future applications

Quality Fit and Finish

Proudly assembled in the USA

PikMore™ Uncaser

StandardKnapp
StandardKnapp
an EMPLOYEE owned company

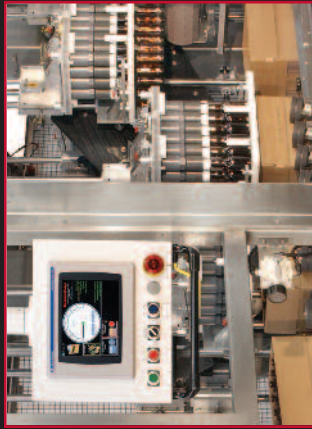

Pik Efficiency

In the event of a mispacked case, the PikMore will continue to operate smoothly without stopping – the faulty pack will simply pass through the machine via the case conveyor to be ejected at a later point in the packaging line.

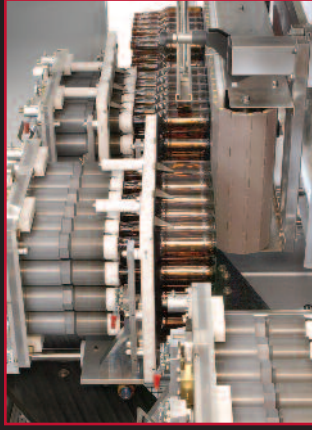

Pik Consistency

The precise handoff between the gripper head and the empty bottle conveyor ensures that the bottles remain upright for the next step in the packaging process.



Pik Autonomy

The PikMore has been designed to operate continuously without an operator present.

The Uncasing Process Explained

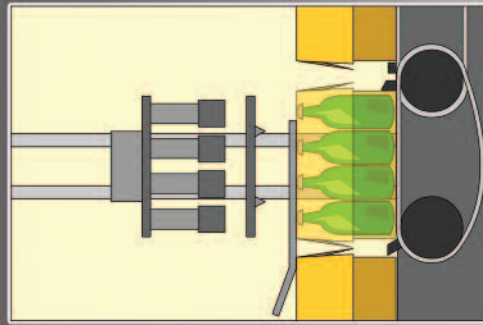

The full case of empty bottles is transported into the machine and enters the hatching area, via customer upstream conveyors.

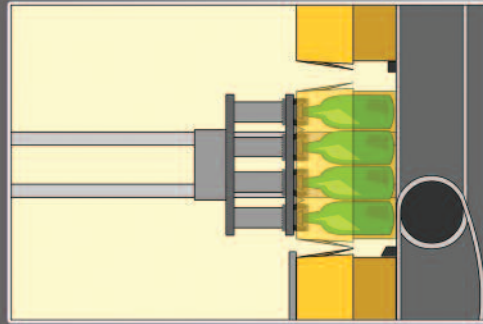

The lowering head tracks the case once it is hatched, positioning the grippers above the bottles.

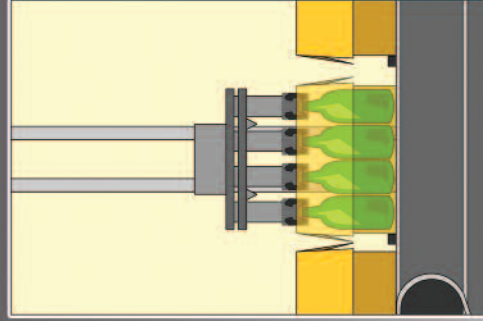

The grippers engage the tops of the bottles by cradling the lip of each bottle's neck.

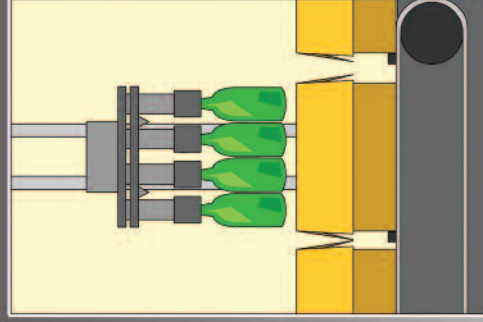

The lowering head raises the bottles up and out of the case, which is held down by retaining wheels.

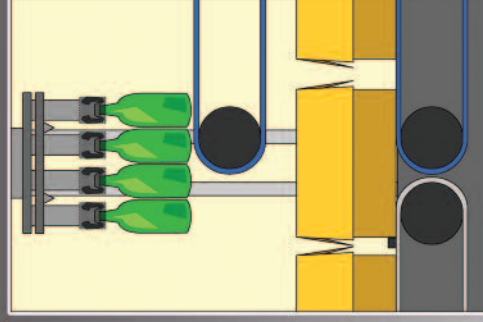

The lowering head, while holding the bottles, is raised up as it advances toward the empty bottle conveyor. The empty case exits the machine on the empty case conveyor.

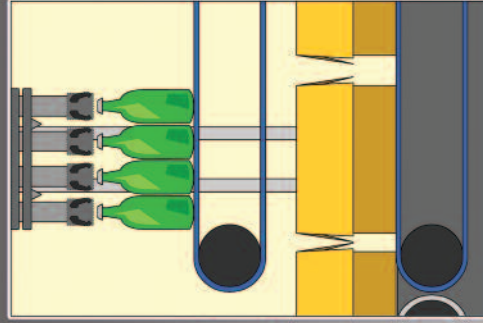

The lowering head gently places the bottles on the speed-matched discharge conveyor and releases them. The lowering head is then raised up and out of the way, returning to its original position to pick more bottles.

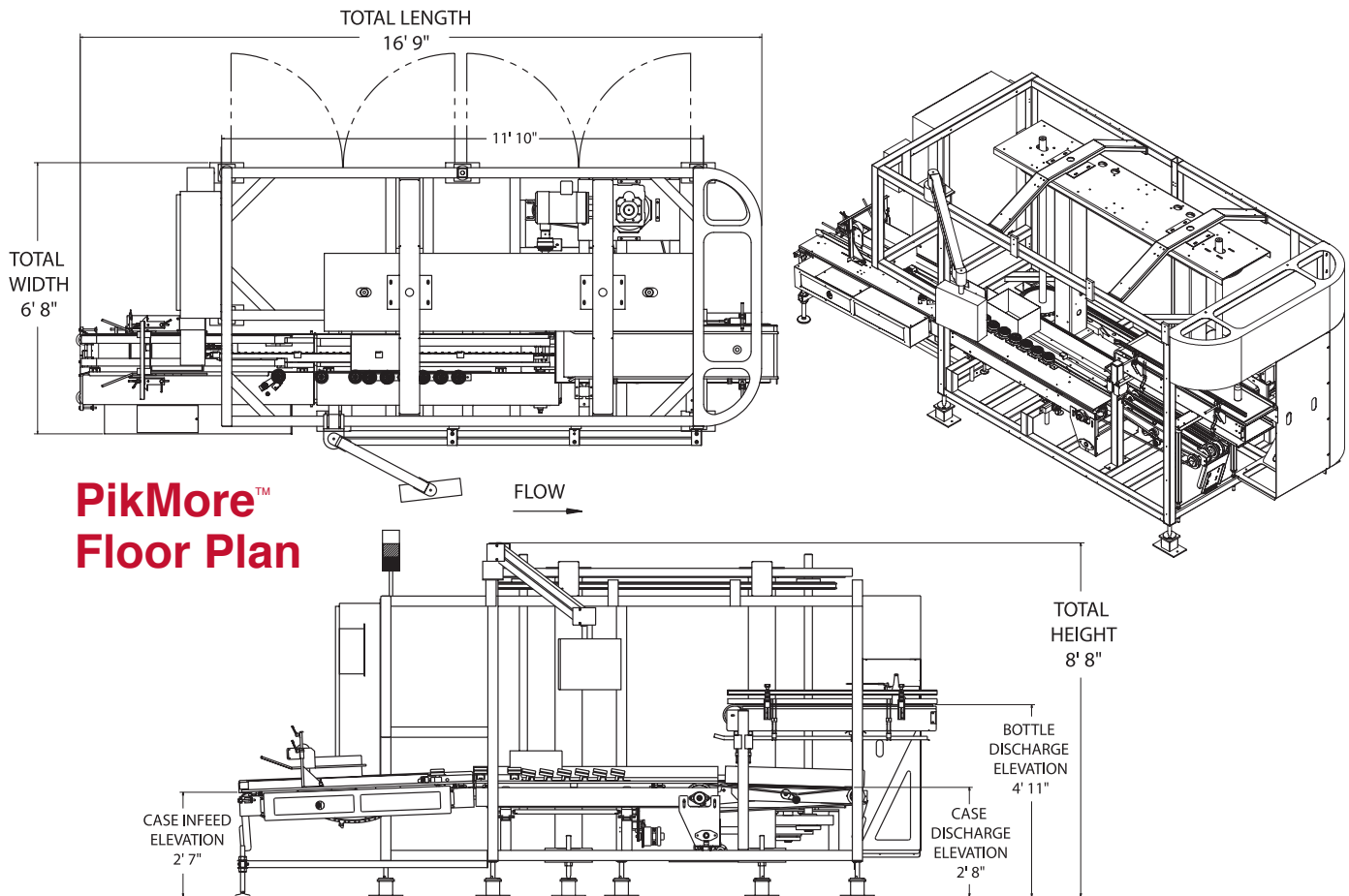

PikMore™ Uncaser Standard Features*

The Standard-Knapp PikMore Uncaser features a stainless steel frame.

Model:	686 PikMore™	Motors:	Main Drive – 5 HP
Speeds:	50 cpm (6 head) 75 cpm (9 head)	Bottle Discharge Drive:	1-1/2 HP
Electrical Supply:	460V	Servo Motors:	None
Air Supply:	80 psi with 1/2 NPT	Bearings:	Sealmaster Goldline Beverage Bearings†
Controls:	Allen-Bradley ControlLogix	Case Control:	Angled Rubber Hold-down Rollers
Interface:	Allen-Bradley PanelView	Operator Alert Beacon:	Tri color stack light
Control Panel:	Stainless Steel Nema 12†	Footprint:	16'9" x 6'8"
Lighting:	Two Vaportite Overhead Lights	Assembled in:	Portland, CT



† Optional

* Standard-Knapp is committed to continuous product improvement. Specifications are subject to change without notice.

StandardKnapp
StandardKnapp
an EMPLOYEE owned company

STANDARD-KNAPP, INC.

63 Pickering Street, Portland, CT 06480 U.S.A.

SALES PHONE: (860) 342-1100, ext. 239

SALES FAX: (860) 342-1557

EMAIL: info@standard-knapp.com

WEB SITE: www.standard-knapp.com